

KFC-HQ101C

SERVICE MANUAL

KENWOOD

Q.C.

COPY

©1991-11 PRINTED IN JAPAN
B51-6397-00(MC) 1513

EXTERNAL VIEW

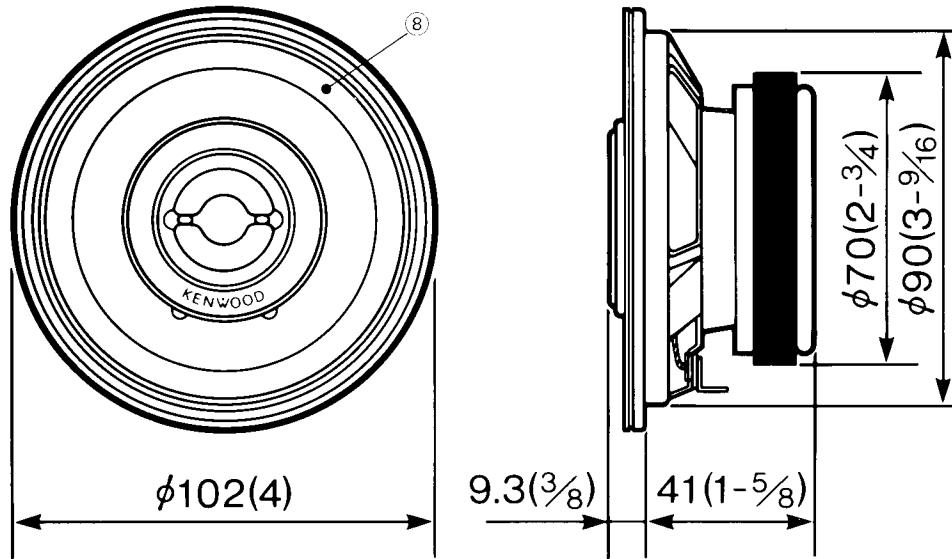

PARTS INCLUDED

- ① φ4×10(φ3/16×3/8).....×4
- ②×6
- ③×6
- ④×4
- ⑤×2
- ⑥ 3 m (10 ft).....×2
(OFC)
- ⑦ 25 cm (0.8 ft).....×2
(OFC)

PARTS LIST

* New parts
Parts without **Parts No.** are not supplied.
Les articles non mentionnés dans le **Parts No.** ne sont pas fournis.
Teile ohne **Parts No.** werden nicht geliefert.

Ref No.	New Parts	Parts No.	Description
①②③④	*	N99-1219-08	SCREW SET
⑤	*	J30-0823-08	SPACER
⑥	*	E30-5112-08	CORD SET
⑦	*	E30-5111-08	CORD SET
⑧	*	T15-0212-08	SPEAKER

FREQUENCY RESPONSE

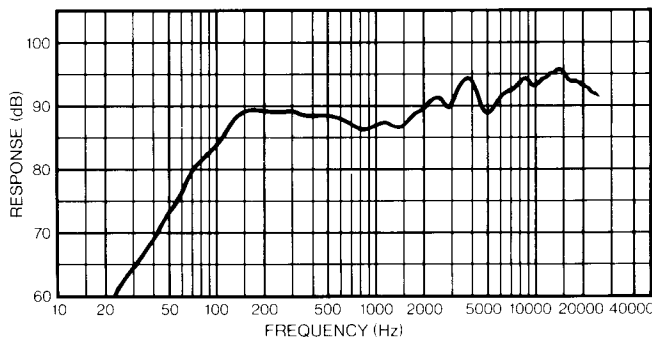

SPECIFICATIONS

- Speakers
- Woofer 100 mm (4 in) P.P. Cone Type
150g (5.3 oz) Magnet
 - Tweeter 25 mm (1 in) P.I-Film Balanced
Dome Type
 - Peak Power 50 Watts
 - Frequency Response 45 Hz~30,000 Hz
 - Sensitivity 89 dB/W at 1m
 - Impedance 4 Ohms
 - Weight Per Speaker 1,040g (2.3 lb)/Pair